

EASYFORM P



Traditional air / steam form finisher with sleeve tensioning arms. Available with or without boiler.

Product codes: 5042, 5052, 5057

DESCRIZIONE: Range of traditional steam/air form finishers with sleeve tensioning arms and electronic control of finishing cycle time. Available with or without boiler. **MODERN** Easyform P is modern technology applied to a traditional form finisher. Easyform P offers features usually found in higher category finishers, such as the pneumatic sleeve clamps and the electronic control board, that allows to program and store common finishing cycles.

CONVENIENT Easyform P is designed for the operator's comfort. The blowing adjustment conveniently located on the front can be shifted with a foot. The pivoting console can be moved to the most convenient position. A single front pedal starts the cycle. **COMPACT** Easyform P has small footprint of 41 x 112 cm. It is available for connection to central steam or with built-in boiler, either 7,5 kW or 15 kW. |

MAIN FEATURES

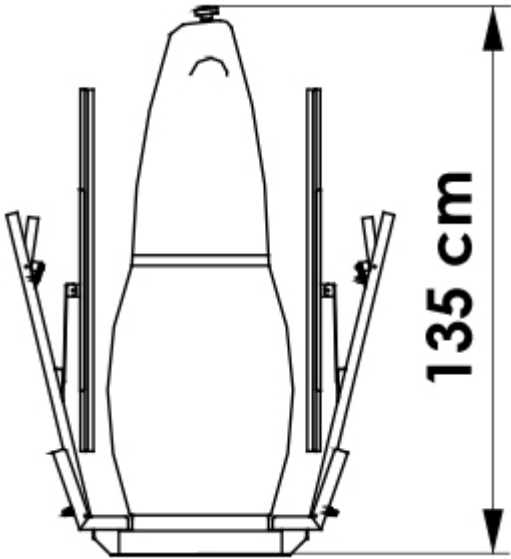

Standard form

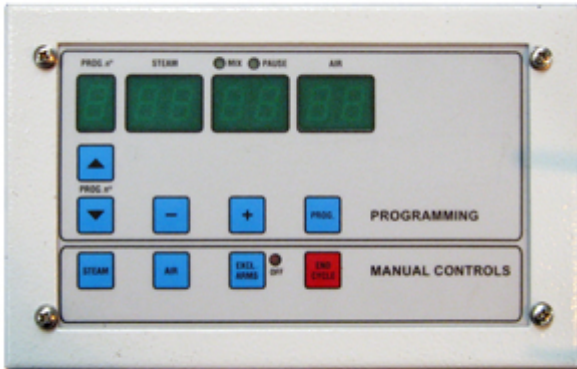

Trevil electronic programmer



Arms for sleeve tensioning

The sleeve tensioning arms allow better ironing of garments with sleeves such as jackets, shirts, blouses, ...

OPTIONS

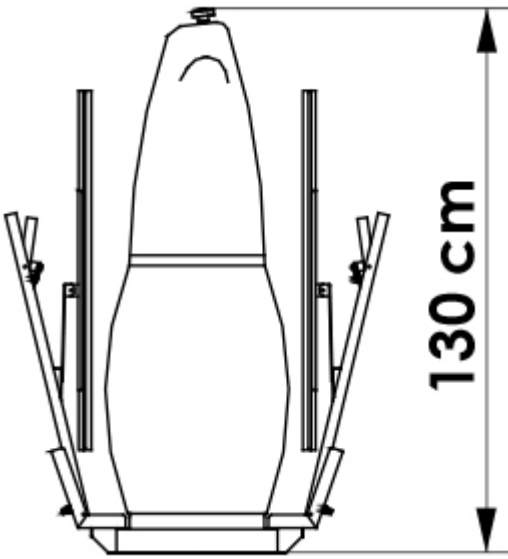

Baby

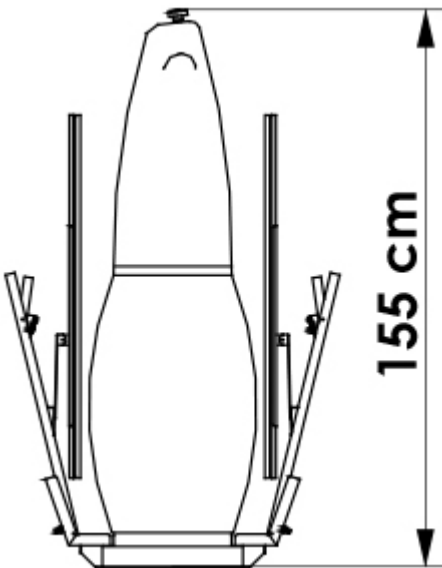

Maxi

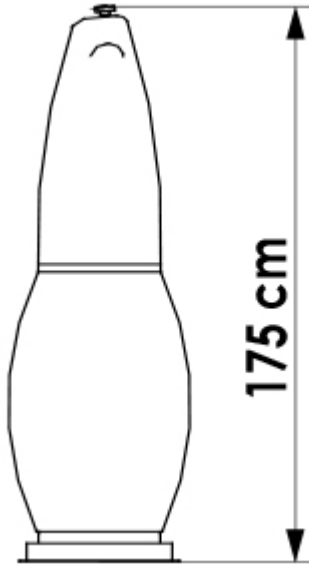

Giant

TECHNICAL SPECIFICATIONS

	5042	5052	5057
Description	Traditional air / steam form finisher with sleeve arms – Without boiler	Traditional air / steam form finisher with sleeve arms – With 7,5 kW boiler	Traditional air / steam form finisher with sleeve arms – With 15 kW boiler
Electrical requirements	400V 3N 50Hz 220V 3 60Hz	400V 3N 50Hz 220V 3 60Hz	400V 3N 50Hz 220V 3 60Hz
Total power	1,1 kW	9,4 kW	16,9 kW
Blowing power	1,1 kW 1,48 HP	1,1 kW 1,48 HP	1,1 kW 1,48 HP
Boiler	–	7,5 kW	15 kW

	5042	5052	5057
Pump power	–	0,6 kW 0,85 HP	0,6 kW 0,85 HP
Steam consumption	15 – 20 kg/h 33 – 44 lbs/h	15 – 20 kg/h 33 – 44 lbs/h	15 – 20 kg/h 33 – 44 lbs/h
Air consumption	5 NI/min 0,18 cfm	5 NI/min 0,18 cfm	5 NI/min 0,18 cfm
Steam pressure	6 bar 87 PSI	6 bar 87 PS	6 bar 87 PS
Air pressure	6 bar 87 PSI	6 bar 87 PSI	6 bar 87 PSI
Footprint	410 x 1120 mm 16"x44"	410 x 1120 mm 16"x44"	410 x 1120 mm 16"x44"
Dimensions	2060 x 1470 x 1720 mm 81" x 58" x 68"	2060 x 1470 x 1720 mm 81" x 58" x 68"	2060 x 1470 x 1720 mm 81" x 58" x 68"
Net weight	88 kg 194 lbs	132 kg 291 lbs	132 kg 291 lbs